

www.chromatographyonline.com

VALIDATION VIEWPOINT



Guest Authors:

Vito Grisanti, (above)
founder of Alpha Tech
Services LLC, and
Edward J. Zachowski,
President of
Alpha Omega
Technologies

Laboratory equipment must be qualified to ensure appropriate and adequate capacity for consistent functioning. One of the first steps in meeting good laboratory and manufacturing practices compliance is to perform installation and operational qualification. In a regulated environment, it is not just an option; it is a matter of law.

Ira Krull and Michael Swartz
Validation Viewpoint Editors

In recent years, many laboratories have taken on the responsibilities of instrument maintenance. Sometimes these duties are assumed to reduce costs, other times to provide a more expedient problem resolution than most service contracts offer.

As a result, some laboratories have experienced a degree of success in allowing their own in-house experts to perform necessary instrument quality-assurance operations. For laboratories choosing to go this route in implementing their own protocol, we thought it would be helpful to discuss some of the issues that should receive careful attention.

In weighing the seemingly competing interests of regulatory compliance versus cost control, users can achieve a balance if an overall increase in laboratory productivity is realized when the procedures are implemented. In this "Validation Viewpoint" column, we will illustrate that a well-managed and well-executed instrument maintenance program can minimize downtime and increase confidence in testing results.

The Four Qs

Everyone working in an analytical laboratory should be concerned about the quality assurance of its laboratory equipment. Quality standards stipulate that all instruments must be adequately designed, maintained, calibrated, and tested. However, quality standards and regulations are not always clear about how to achieve this goal. The approach that has been adopted in the environment of the analytical instrument has become known as the *Four Qs*—*design qualification (DQ)*, *installation qualification (IQ)*, *operational qualification (OQ)*, and *performance qualification (PQ)*.

Design qualification happens at the vendor's site, and it is representative of the way an instrument is developed and produced, usually governed by International Organization for Standardization (ISO) criteria.

The installation qualification process can be divided into two steps: *preinstallation* and *physical installation*. During preinstallation, all information pertinent to the proper installation, operation, and maintenance of the instrument is reviewed. Workers confirm the site requirements and the receipt of all of the parts, pieces, and manuals necessary to perform the installation. During physical installation, serial numbers are recorded and all fluidic, electrical, and communication connections are made for system components. Documentation describing

how the instrument was installed, who performed the installation, and other miscellaneous details are archived.

The operational qualification process ensures that the specific modules of a system are operating according to the defined specifications for accuracy, linearity, and precision. This process might be as simple as verifying a module's self-diagnostic routines or might be more complex such as running specific tests to verify detector wavelength accuracy, flow rate, or injector precision.

The performance qualification step verifies system performance. Performance qualification testing is conducted under actual operating conditions throughout the anticipated working range. In practice, however, operational and performance qualification frequently blend together, particularly for linearity and precision (repeatability) tests, which can be conducted more easily at the system level. For high performance liquid chromatography (HPLC), the performance qualification test should use a method with a well-characterized analyte mixture, column, and mobile phase. It should incorporate the essence of the system suitability section of the general chromatography chapter (621) in the *U.S. Pharmacopeia (1)*. Again, proper documentation should be archived to support the performance qualification process. In this discussion, we will focus our attention on the third step of the process, operational qualification, and provide some additional information about performance qualification.

Operational Qualification Testing

After the initial installation of hardware and software, the next step should be conducting an operational test. In the pharmaceutical manufacturing environment, this process is called operational qualification. Following the initial installation test, the operational qualification should be repeated at defined intervals. The goal of this test is to demonstrate that the system operates as intended after placement in a user's environment. Testers take a holistic approach whenever possible to ensure proper installation and good system integration.

The terms *validation* and *qualification* often are used erroneously to represent the same concept. Actually, *qualification* is instrument oriented, and it primarily is a confirmation of evidence that supports the satisfactory performance of an instrument. *Validation*, on the other hand, is application oriented and relates to a specific measurement method or process.

It is important to understand that after an instrument undergoes qualification, it must be treated as one entity. This concept can represent a major shift in thinking for laboratory workers who enjoy the benefits of system modularity (for example, a system that comprises individual modules such as solvent delivery, autosampler, and detector modules) and occasionally move a module to another system to address faulty conditions with one system to bring it on-line again.

Something as basic as a firmware revision can illustrate the importance of the holistic approach. Firmware, of course, is the low-level software incorporated into these instruments that provides algorithms for the internal operations and physical access controls. Detector systems, which measure analyte response, can use various analog-to-digital converters. The methodology of analog sampling and the manner in which the software handles the data all are controlled by firmware (2). The variations of how these electronic and software interactions occur in an instrument are numerous, and they are invariably different as implemented by individual instrument manufacturers.

Users of these systems have become familiar and even comfortable with these differences - as long as any system is qualified for performance and calibrated so that the results generated are equivalent and viable, regardless of the instrument from which they came. What many users fail to consider, however, is the effect different firmware revisions can have on instrument performance and compatibility when they switch modules between systems. Swapping modules of the same make and model number does not negate the concern, because many firmware revisions exist for the same make and model and often only factory-trained personnel can ascertain the significance of a swap. Analysts often must account for hardware revision considerations or performance issues of each module.

Operational Qualification Specifics

Operational qualification verifies key aspects of instrument performance without the aspects of any contributory effects that could be introduced by a method. The goal is to verify that the main operating parameters— injection volume, flow rate, mobile-phase mixing, column thermostating temperature, and detection wavelength—are within their specified limits for accuracy and precision. This verification gives users confidence that an instrument is operating correctly to specifications and that a parameter's selected and actual values have no unacceptable differences. For example, if a pump is set to deliver 1.0 mL/min, then the actual flow should be within required tolerances (0.95-1.05 mL/min) and not significantly different (for example, 0.7 or 1.3 mL/min) from the selected value (3). For an automated gas chromatograph or a gas chromatography mass spectrometry system, operational testing can mean verifying correct computer communication between the computer and the equipment and checking the detector response and the precision of the retention times and peak areas (4).

In practice, testing individual instrument parameters, relative to accepted tolerances, requires isolating each parameter. Each parameter is consistent with an HPLC function; Figure 1 illustrates typical HPLC functions. Isolating a parameter as much as possible for testing ensures relevant results. Naturally, we would have greater confidence in the results if potentially contributory errors were eliminated and if testing was limited strictly to the responsible mechanism.

Table I lists some typical parameters of interest and the reasons why they are tested. Most HPLC systems today truly are modular in nature, and these parameters are inherent to modules. Although we are purporting the holistic approach, the parameters are delineated by

module for practical purposes. Initially, this approach might seem paradoxical, but it is not. Consider a parameter such as injection-volume precision, which customarily is determined by observing the reproducibility of detector response. Obviously, an observer cannot be entirely sure when the detector is responding reproducibly or vice versa. Measuring one parameter creates reliance upon another, which demonstrates that qualification really is for a system, which is treated as a single entity. For this reason we describe as holistic, with the isolation of parameters being a pragmatic means to an end.

Many quality standards and enforcement authorities stipulate that "where possible calibrations should be traceable to national or international standards" to ensure accuracy (5). This requirement causes confusion about the need for traceable standards and calibrated apparatus when checking an instrument's operating parameters. Tests to verify the accuracy of critical parameters such as wavelength accuracy will necessitate the use of traceable standards and calibrated equipment (3).

The frequency period of operational qualification testing will depend on a variety of factors, including

- the manufacturer's recommended interval,
- the user's required instrument performance,
- the instrument's activity (high-activity equipment might need more frequent operational qualification testing because of excess wear), and
- the application's nature (for example, highly corrosive mobile phases will attack pumps and injectors).

The event-driven operational qualification, which is separate from frequency testing, also has a role that affects the performance of a system. In this situation, events such as lamp replacement, flow-cell rebuilding, and injector valve seal replacement, necessitate repeating an operational qualification for the particular module.

Relocating or moving an instrument, routine preventative maintenance, upgrades (firmware or software), or modifications are other examples of reasons to perform operational qualification. Analysts must use their best chromatographic judgement to decide which relevant tests should be performed. After successful completion of operational qualification,

a qualification sticker should be placed on the equipment in an easily visible place to inform users of the instrument's compliance. The sticker should indicate the date the test was performed (operational qualification), the expiration date, and the signature of the tester. The instrument's logbook also should contain an entry with the same information.

Table 1: Detail of Operational Qualification for Various HPLC Instruments

Parameter	Reason	Comments
Autosamplers and Injectors		
Injection-volume accuracy	Important only in rare cases that require accurate injections or specialized liquid-handling before analysis	Although isolated modular testing of injection-volume accuracy is possible, analysts normally focus on injection-volume precision, which is more important.
Injection-volume precision	Key to system repeatability and result precision	Can be determined from a sample's relative standard deviation; in practice, it is measured holistically by observing the reproducibility of detector response relative to repeated injections using the same injector program.
Injection-volume linearity	Important only in rare cases in which injection volumes are not held constant	Although isolated modular testing of injection-volume linearity is possible, most methods use constant volumes of sample and standard, thereby muting its significance. Again, analysts normally focus on injection-volume precision, which is more important.
Solvent-delivery Systems		
Flow-rate accuracy	Potentially important in obtaining results that are comparable between systems	Can be determined by measuring the volume of mobile phase delivered under a suitable back pressure during a period of time.
Flow-rate precision	Can affect retention times, peak shape, and integration results; potentially important in obtaining results that are comparable between systems	Can be determined by performing repeated flow-rate accuracy measurements throughout time.
Gradient accuracy	Potentially important in obtaining results that are comparable between systems	Can be determined at a modular level by introducing an additive through one of the solvent channels and independently measuring its concentration in the mobile phase as a function of the programmed increases or decreases of that particular solvent channel.
Gradient precision	Can affect retention times, peak shape, and integration results; potentially important in obtaining results that are comparable between systems	Can be determined by performing repeated gradient accuracy measurements throughout time.
Column ovens		
Thermostating accuracy	Potentially important in obtaining results that are comparable between systems	Determined by measuring the temperature inside the column compartment relative to the instrument's set point; must use calibrated device.
Thermostating precision	Could affect retention times and detector response; potentially important in obtaining results that are comparable between systems	Can be determined by performing repeated temperature accuracy measurements during a period of time.
Detectors		
Wavelength accuracy	Important in determining overall accuracy of results and validating migrating methods to other systems	Typically determined by comparing a measured absorbance with the absorbance maxima of a reference material such as a holmium oxide filter.
Response linearity	Important for accuracy of results throughout a range of expected concentrations	Analysts should expect to obtain a linear relationship between the signal amplitude and the concentration of analyte.
Signal-to-noise ratio	Plays a role in determining a system's minimum detection limits	Can be determined by measuring the random fluctuations of a signal's amplitude throughout time.
Data-handling systems		
Accuracy and precision	Must provide accurate and precise measurement of chromatographic peaks and deal properly with partially resolved, broad, or asymmetric peaks	Can be verified using special software or peak-output simulators, but it generally is accepted that proper operation is confirmed by obtaining satisfactory results from operational qualification testing of the complete system.

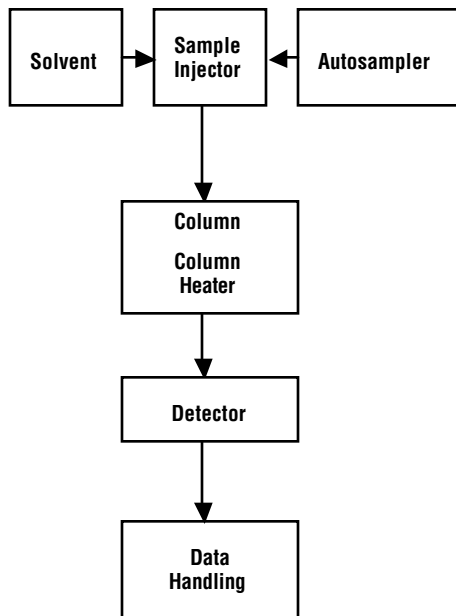

Figure 1: Typical HPLC functions subjected to qualification testing.

Performance Qualification Testing

In performance qualification, analysts ascertain that an instrument consistently performs according to a specification determined by its routine analysis. The initial performance qualification as performed by a vendor (usually after an operational qualification) is analyzed using a vendor test mix, a test column, and defined operating parameters. An analyst compares the performance results with data obtained in the past or in the future. This information is important, especially to vendors trying to diagnose potential hardware issues. They can establish common and predictable evidence about whether an instrument is functioning correctly. During routine use, however, the actual conditions of the system can vary significantly from this defined test system. It is, therefore, necessary that users perform checks and tests to demonstrate satisfactory instrumental performance during actual use. It is highly likely that a system's performance gradually will be affected because of normal wear or system failures. We recommend performing a system-suitability test before and during analysis studies. A system-suitability test provides assurance that a system's performance still is appropriate for use.

Performance qualification, therefore, is a test that is executed more frequently than operation qualification. The specifications can be determined and documented during analytical method development and valida-

limits of detection, amount precision, resolution, tailing factor, and retention-time precision. In many computer-based data-acquisition systems, these tasks can be automated, performed easily, and documented during system-suitability testing. Hence, system performance can be measured continuously and documented daily or with every instrument use. A system-suitability test most likely will identify an HPLC system problem before an analysis exhibits it. Flow irregularity, injector precision, column problems, and detector noise are a few of the possible events that can occur and cause failure of the system-suitability test. Laboratories should have documented procedures that users can follow if a system falls out of specification.

Ultimately, users should perform these tests at a defined interval. This interval can be every day, every month, or any time the instrument is in use.

Conclusions

Some people question the value of maintenance programs, but many believe that they provide tangible benefits in reduced downtime and increased productivity (6). Some laboratories find that using in-house resources for these programs is a good fit; others will want the benefits provided by deploying factory-trained personnel from the instrument manufacturer or a qualified third party. Some laboratories prefer to rely upon outside sources because they can have their systems documented by a potentially more impartial party, avoid having their own personnel get bogged down with extremely labor-intensive operational qualification tasks such as gradient qualification, have fast response by factory-trained and qualified personnel, gain potential cost benefits by preserving laboratory personnel for core lab-oratory activities, reduce instrument-specific training requirements for laboratory personnel, and have expedient scheduling of event-driven operational qualification to ensure instrument uptime.

If a laboratory wishes to pursue in-house alternatives, we suggest that laboratory management seriously consider special service training for their personnel. This training will provide greater assurance that the program is being implemented effectively. We recommend that these workers obtain and retain records of their training. These records show that the parties engaged in the qualification are capable of doing the work and have verified all test results.

The qualification of instruments does more than bring companies into regulatory compliance. It assures chromatographers of the limits and abilities of their systems and

Improves confidence in their analytical results. Qualification is important in the development and transfer of methods to laboratories within or outside its company. Chromatographers should not discount the value of qualification programs. Qualification has become a part of doing business within regulatory environments and should be considered a benchmark for laboratory quality. Companies must pay attention to these processes and determine the best economical framework for continued confidence in the information supplied by a laboratory.

References

- (1) *U.S. Pharmacopeia 24-National Formulary 19* (U.S. Pharmacopeial Convention, Rockville, Maryland, 1999).
- (2) H.H. Bauer, G.D. Christian, and J.E. O'Reilly, in *Instrumental Analysis* (Allyn & Bacon, Inc., Boston, 1978), pp. 750-757.
- (3) P. Bedson, *National Measurement System 1997-2000 Valid Analytical Measurement (VAM) Programme* (LGC, Teddington, United Kingdom, 1998), p. 6.
- (4) L. Huber, *Accreditation and Quality Assurance* 10), 7 (1998).
- (5) P. Bedson, *National Measurement System 1997-2000 Valid Analytical Measurement (VAM) Programme* (LGC, Teddington, United Kingdom, 1998), p. 7.
- (6) M. Zoubair El Fallah, *LCGC* 17(5), 434 (1999).

Vito Grisanti

is the founder of Alpha Tech Services LLC, a professional organization involved in the service and maintenance of analytical instrumentation. Mr. Grisanti has over 22 years of service experience.



Alpha Tech Services LLC provides on-site service and support for gas and liquid chromatographs, as well as IQ, OQ and PQ qualification services. AlphaTech Services is located in Westwood, NJ. **Website: www.Alphatech-Services.com**

Edward Zachowski

is President of Alpha Omega Technologies, a full service provider of laboratory instruments and supplies, based in Brielle, NJ. Besides rentals, leases, and instrument trade-ins, the company has introduced GEANNA, a new High Speed Refinery Gas Analyzer, which can complete an entire analysis suite in less than 60 seconds. Web Site: www.alphaomeciatech.com/ or www.aoti.net/.

